



Customer
SUCCESS
STORY

REMOTE SPECTRUM MONITORING CASE STUDY

Getting FAA Approval to Install Transmitter Solution Near an Airport

THE CHALLENGE

One of our customers recently had a project involving the connection of a small RF transmitter to a large antenna array near an airport. In order to avoid catastrophic spurious emissions, they were required to report any incidences of potential jamming to the FAA. This would occur if the frequency sweeps of their antenna fell into the communication range of commercial aircraft.

The company focuses on remote sensing solutions for complex problems and needed to deploy a low-cost remote signal monitoring system that would remain at the airport and deliver data, analytics, and alerts. They needed to design a solution for seamless remote management, enabling power cycling, system recovery and pushing out any software updates without requiring the physical assistance of a field technician.

THE SOLUTION

Our customer found out about Signal Hound's SA44B spectrum analyzer from their client. After reviewing the datasheet, they felt that the price/performance ratio was ideal for their application. The Signal Hound device offered faster frequency sweeps than competing products, and after exploring the device, they found the API easy to use and automated the system for their field operations.

“Thanks to the SA44B's size and power use, a battery-based micro-ATX Windows PC was able to control the entire solution.”

-FAA Contractor

SIGNAL HOUND SWEEP SPEEDS

SA44B	140 MHz/s \geq 10 kHz RBW
BB60C	224 GHz/s \geq 30 kHz RBW
SM200B	1 THz/s \geq 30 kHz RBW

Sweep speed is of critical importance for spectrum monitoring.

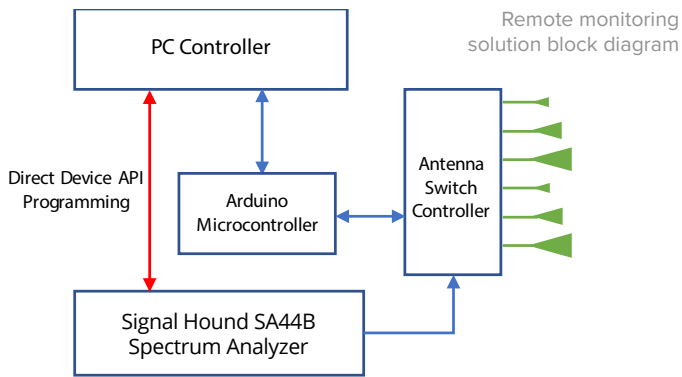

Our customer put together some C-code on an outdoor industrial computer to automate for periodic data collection. They integrated a small antenna rotator with an Arduino connected to the computer in order to select different antennas for re-evaluating the frequency spectrum. Thanks to the SA44B's size and power use, a battery-based micro-ATX Windows PC was able to control the entire solution.

Signal Hound's spectrum analyzer architecture also offered additional performance benefits. In many cases, an instrument's software can consume computer processor overhead which both slows the overall speed and increases battery usage. Signal Hound allows users to bypass the Spike software application for direct device API programming. The Signal Hound spectrum analyzers can be programmed in C++, LabVIEW, MATLAB, Python, C# or any language that has C bindings.

THE RESULTS

For our customer, the key benefit of using the Signal Hound spectrum analyzer was the ease of automating field data collection through our API. This allowed them to repeatedly generate a table of fast measurements across a broad frequency band. This data was then summarized over the course of multiple days via their remote sensing package, located at the end of an airport runway. The SA44B's low power use allowed the battery-based micro-ATX Windows PC to collect long periods of data on a single charge. They then used MATLAB to generate 3-D plots of the RF spectrum of interest versus time. These reports were consolidated and kept as a log to show the FAA as proof that they were compliant during testing. In the end, the results showed that the experimental antenna redesigns were not radiating signals that could disrupt tower communications with aircraft. The Signal Hound spectrum analyzer worked well and proved to be reliable and trustworthy enough for FAA acceptance of the data. The ability to use the SA44B in their automated solution made it an overall winner for both our customer and theirs.

SIGNAL HOUND SOLUTIONS

Across a wide range of industry and specialized applications, high-quality spectrum analysis has become a "go anywhere" necessity for supporting field and remote deployments. Signal Hound is working closely with our customers in a wide variety of spectrum monitoring applications. Our spectrum analyzers meet your key requirements of performance and affordability, and they can easily be integrated into your monitoring system. Our open-systems approach provides a highly extensible platform for creating custom-tailored spectrum analysis applications.



Signal Hound®

Delivering Unrivaled Value in RF Test and Measurement Equipment.