

TEST EQUIPMENT PLUS

Signal Hound USB-SA44B

Calibration Manual

TEST EQUIPMENT PLUS

Signal Hound USB-SA44B Calibration Manual

© 2011, Test Equipment Plus
35707 NE 86th Ave
Phone (360) 263-5006 • Fax (360) 263-5007

Table of Contents

| | | |
|----------|---|----------|
| 1 | CALIBRATING | 1 |
| 1.1 | Calibration Cycle | 1 |
| 1.2 | Lab Standards | 1 |
| 1.2.1 | Table of Required Lab Standards | 2 |
| 1.3 | Performance Verification Tests | 2 |
| 1.3.1 | Self Test | 2 |
| 1.3.2 | Automated Calibration Test Setup | 3 |
| 1.3.3 | Running the Automated Test | 4 |
| 1.3.4 | Viewing the Calibration Test Report | 4 |
| 1.3.5 | If You Have a Problem | 5 |
| 2 | SPECIFICATIONS..... | 6 |
| 2.1 | Frequency..... | 6 |
| 2.2 | Amplitude (RBW \leq 100KHz) | 6 |
| 2.3 | Sweep | 7 |
| 2.4 | Measuring Receiver | 7 |
| 2.5 | Inputs and Outputs..... | 7 |
| 2.6 | Environment | 8 |
| 2.7 | Calibration..... | 8 |
| 2.8 | Adjustments | 8 |
| 2.9 | Optional Accessories..... | 8 |
| 3 | WARRANTY AND DISCLAIMER | 9 |
| 3.1.1 | Warranty..... | 9 |
| 3.1.2 | Warranty Service | 9 |
| 3.1.3 | Limitation of Warranty | 9 |
| 3.1.4 | Exclusive Remedies | 10 |
| 3.1.5 | Certification | 10 |
| 3.1.6 | Credit Notice..... | 10 |

1 Calibrating

Identify Lab Standards and Procedures to use for the Signal Hound Calibration

This chapter discusses the equipment required for Signal Hound USB-SA44B calibration, the calibration procedures to be followed, and what to do if one or more tests fail. Most of the procedures are automated and will be run on a PC with a GPIB interface from Agilent or National Instruments. None of the procedures require opening up the Signal Hound enclosure or modifying the calibration constants.

All tests should be performed using calibrated instruments specified in this chapter. The automated test exercises the major circuits and functions of the USB-SA44B.

1.1 Calibration Cycle

A one year calibration cycle is recommended.

1.2 Lab Standards

Most tests are automated over GPIB. Standard **Agilent VISA** drivers are used, and a National Instruments or Agilent GPIB adapter is required. USB or PCI GPIB adapters are supported. You will need the Agilent libraries installed to use National Instruments GPIB devices as well.

One or more RF Signal Generators are required. The frequency range from 500 KHz to 4.4 GHz must be covered. Generators that use the SCPI protocol over GPIB may be used. Additionally, any generator that uses the same protocol as the HP 8340A/B, also called "analyzer" protocol, may be used.

An RF splitter is required. A calibrated HP 11667B is ideal.

An RF power meter and sensor is required. An HP E4418A/B or E4419A/B, with an E9304A power sensor is required.

CALIBRATING

The Signal Hound is calibrated using a Windows® based PC using our application software. A quad core processor with Windows XP or newer is recommended.

1.2.1 Table of Required Lab Standards

| Equipment Type | Recommended Make / Model |
|--|---|
| Signal Generator 1: 500 KHz to 20 MHz | HP/Agilent 8644B. NOTE: If you have an 8665B or similar, that covers 500 KHz to 4.4 GHz, one generator will suffice |
| Signal Generator 2: 10 MHz to 4.4 GHz | HP 8340 A/B |
| RF Power Splitter | HP / Agilent 11667B |
| Fixed RF Attenuator, 10 dB, low VSWR | HP / Agilent 8493C. Note: The actual attenuation vs frequency must be known to enter correction factors |
| RF Power Meter | HP / Agilent E4418 A/B or E4419 A/B |
| RF Power Sensor | HP / Agilent E9304A |

Additionally, a 3 ft BNC cable and BNC-to-SMA adapter will be required, as well as type N to SMA and SMA to SMA adapters as needed for test setups.

1.3 Performance Verification Tests

Performance tests shall be run at 20°C to 25°C.

1.3.1 Self Test

Perform a self test using a 3 ft BNC cable and BNC-to-SMA adapter, by connecting the RF input to the Self Test Output, then launching the Self Test Utility. Record results.

CALIBRATING

1.3.2 Automated Calibration Test Setup

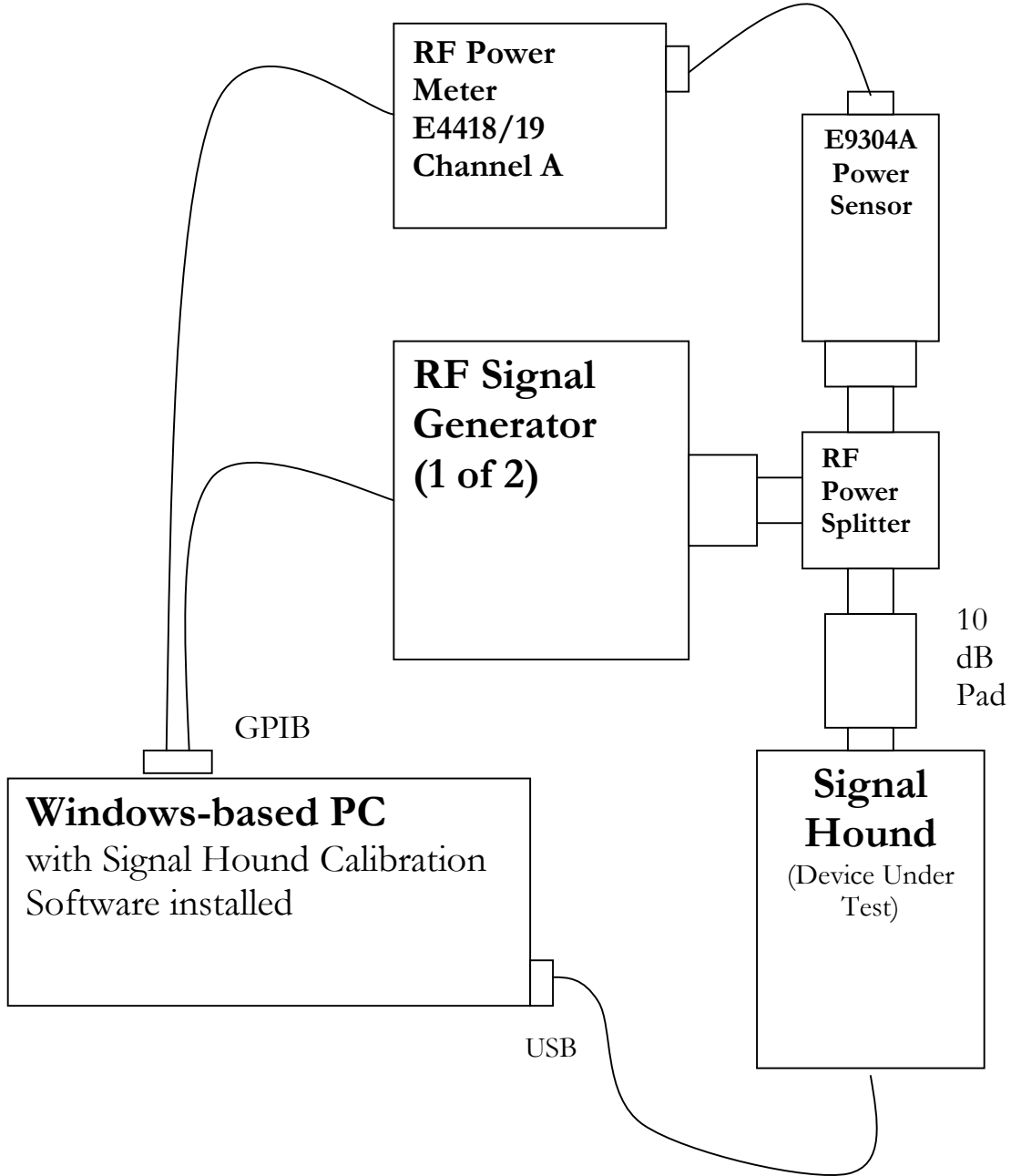
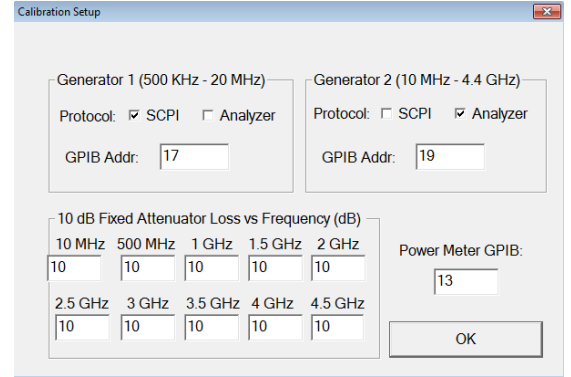

Figure 1: Automated Test Setup

CALIBRATING

1.3.3 Running the Automated Test

1. Set up your equipment as shown in the previous section. Connect both signal generators to the GPIB bus. The 4.4 GHz signal generator is used first.
2. Set BOTH generators to an initial state of CW, RF ON, -10 dBm.
3. Zero and Calibrate your power sensor.
4. Launch the Signal Hound Calibration Software
5. From the Menu, select **Utilities→Testing→Calibration**
6. Enter the GPIB address and language for each device. If you are using a single generator, enter its GPIB address for both. Enter the actual attenuation for the 10 dB pad at the 10 points listed. Then click **OK**. This information will be stored to the registry and automatically loaded each time you use the calibration utility.
7. Follow the instructions. You will be prompted to switch to the 500 KHz signal generator after about 5-10 minutes, for the last 1-2 minutes of the test.



1.3.4 Viewing the Calibration Test Report

Once the test is complete, a text-based calibration report will be opened in another window. This is a report of the test points checked and the amplitudes or frequencies reported. Check the bottom of the report for an overall **PASS**. You may use this as your calibration test data for the purpose of verifying that the Signal Hound performance is within published specifications. You may save this data to a location of your choice by selecting **File→Save As...**

CALIBRATING

1.3.5 If You Have a Problem

Before contacting Test Equipment Plus, check the basics:

1. Are all RF cables and connectors tight and in good condition?
2. Is the Signal Hound operating (is the LED green, with orange flashes each sweep)?
3. Double check the hardware setup and software configuration and retest.

If the Signal Hound needs adjustment please contact Test Equipment Plus for an RMA.

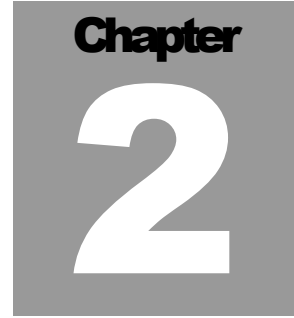

2 Specifications

Unless otherwise stated, specifications are valid for an ambient temperature range of 0 to 70°C (or -40 to +85°C for option 1), image rejection on, amplitude of signal applied less than the reference level.

2.1 Frequency

Frequency Range: 1 Hz to 4.4 GHz

Span Modes: (Center Frequency + Span) or (Start + Stop Frequencies)

Maximum Span: 4.4 GHz

Minimum Span: 10 Hz or Zero Span

Internal Frequency Reference Accuracy: ± 1 ppm

For greater frequency accuracy connect to external 10 MHz timebase (0 to +20 dBm)

Frequency Readout Accuracy: reference error ± 1 sweep point ⁽¹⁾

Marker Accuracy: reference error ± 1 sweep point

Resolution Bandwidth: 0.1Hz to 250KHz and 5MHz⁽²⁾

Spectral Purity

Residual FM, 3KHz Audio LPF, 15 KHz IF BW: **[0.1 Hz + 4 Hz / GHz] typical RMS FM** (e.g. 2 GHz RF would have 8.1 Hz RMS FM). Increasing IF BW increases residual FM.

Note 1: 1 sweep point represents approximately 40% of the selected RBW for 1 Hz to 100 KHz RBW.

Note 2: 5 MHz RBW accuracy not specified

2.2 Amplitude (RBW \leq 100KHz)

Range: 1dB Gain Compression to Displayed Average Noise Level (DANL)

1dB Gain Compression: (attenuator set to 15dB, preamp off)

+16dBm Typical, 1Hz to 150MHz

+19dBm Typical, 150MHz to 4.4GHz

Displayed Average Noise Level: 0dB input attenuation, 1Hz RBW

| Frequency | RF Preamp Off | RF Preamp On |
|------------------|---------------|--------------|
| 10Hz | -124 dBm | NA |
| 100Hz to 10KHz | -130 dBm | NA |
| 10KHz to 500KHz | -142 dBm | NA |
| 500KHz to 10MHz | -142 dBm | -153 dBm |
| 10MHz to 100MHz | -148 dBm | -161 dBm |
| 100MHz to 1GHz | -144 dBm | -158 dBm |
| 1GHz to 2.6GHz | -139 dBm | -151 dBm |
| 2.6GHz to 3.3GHz | -135 dBm | -151 dBm |
| 3.3GHz to 4.4GHz | -128 dBm | -134 dBm |

Absolute Accuracy (Reference level \leq 0 dBm): ± 1.5 dB, no warm-up required

SPECIFICATIONS

Absolute Accuracy (0 dBm < Reference level ≤ 10 dBm): ±2.0dB

Relative Accuracy (Reference level ≤ 0 dBm): ±0.25 dB

Maximum Safe Input Level (preamp off, 15 dB atten): +20dBm

DC Volts: < ±0.2V absolute maximum

Residual Responses (Input terminated, ≤100 KHz span, 0 dB atten, preamp on): <-80 dBm¹

Note 1: Known residual responses at multiples of 10 MHz

Spurious Responses (≤100 KHz span, CW tone input): , < -80 dBm typical

| Typical Maximum LO Feedthrough (preamp on, attenuator set to 15 dB) | |
|---|---------|
| 1Hz to 500KHz* | -70 dBm |
| 500KHz to 1GHz | -57 dBm |
| 1GHz to 2.3GHz | -47dBm |
| 2.3GHz to 2.6GHz | -40 dBm |
| 2.6GHz to 3.0GHz | -27 dBm |
| 3.0GHz to 4.4GHz | -35 dBm |

*RF Preamp Off and Internal input Attenuator on any setting

2.3 Sweep

Zero Span Sweep Time 0.1 ms to 10 sec, ± 0.1%

All other sweeps times are estimates reported after sweep completes.

Maximum sample rate: 486K/sec

Sweep Trigger: free run, single, video, external

External Trigger: 3.3V CMOS/TTL input

2.4 Measuring Receiver

FM Accuracy ±1% typical

AM Accuracy ±1% typical

Synchronous Level Detector (15 KHz IF BW, timebases locked)

100 KHz to 1 GHz +0 dBm to -125 dBm after 10 min warmup **±0.25dB typical**

1 GHz to 4.4 GHz +0 dBm to -115 dBm after 10 min warmup **±0.25dB typical**

Average Level Detector, 15 KHz IF BW

100 KHz to 4.4 GHz +0 dBm to -70 dBm after 10 min warmup, **±0.25dB typical**

Maximum IF Bandwidth 240 KHz

Audio Filters:

Low Pass: Digital Windowed Sinc, selectable cutoff

Band Pass: Selectable center frequency, narrow-band recursive, 160 Hz 3 dB bandwidth

Maximum sample rate: 486K/sec

2.5 Inputs and Outputs

- 1) **BNC External Timebase** (10 MHz input)
- 2) **BNC Shared**
 - Self Test Output
 - SYNC Out
 - Sweep Trigger In
- 3) **SMA RF Input**

SPECIFICATIONS

2.6 Environment

Operating Temperature: 0 to +70 °C (std), -40 to +85°C (option 1)

2.7 Calibration

Test with factory calibration software to verify that USB-SA44B is operating within tolerance. Recommended calibration interval is 1 year.

2.8 Adjustments

Factory adjustments shall be used to generate new calibration constants when USB-SA44B will not pass calibration. Contact Test Equipment Plus for an RMA for adjustments. Temperature correction data is generated only at time of manufacture.

2.9 Optional Accessories

- 1) 20dB Fixed Attenuator, Mini Circuits Part # **VAT-20+**
- 2) DC Block, Mini Circuits Part # **BLK-89+**
- 3) SMA(m) to BNC(f) Adapter, Mini Circuits part# SM-BF50+
- 4) 3GHz RF Probe, p/n P-20A (made by Auburn Technology, www.auburntec.com)

3 Warranty and Disclaimer

Copyright © 2011
Test Equipment Plus
All rights reserved

Reproduction, adaptation, or translation without prior written permission is prohibited, except as allowed under the copyright laws.

3.1.1 Warranty

The information contained in this manual is subject to change without notice. Test Equipment Plus makes no warranty of any kind with regard to this material, including, but not limited to, the implied warranties or merchantability and fitness for a particular purpose.

Test Equipment Plus shall not be liable for errors contained herein or for incidental or consequential damages in connection with the furnishing, performance, or use of this material. This Test Equipment Plus product has a warranty against defects in material and workmanship for a period of one year from date of shipment. During the warranty period, Test Equipment Plus will, at its option, either repair or replace products that prove to be defective.

3.1.2 Warranty Service

For warranty service or repair, this product must be returned to Test Equipment Plus. The Buyer shall pay shipping charges to Test Equipment Plus and Test Equipment Plus shall pay UPS Ground, or equivalent, shipping charges to return the product to the Buyer. However, the Buyer shall pay all shipping charges, duties, and taxes, to and from Test Equipment Plus, for products returned from another country.

3.1.3 Limitation of Warranty

The foregoing warranty shall not apply to defects resulting from improper use by the Buyer, Buyer-supplied software or interfacing, unauthorized modification or misuse, operation outside of the environmental specifications for the product. No other warranty is expressed or implied. Test Equipment Plus specifically disclaims the implied warranties or merchantability and fitness for a particular purpose.

3.1.4 Exclusive Remedies

The remedies provided herein are the Buyer's sole and exclusive remedies. Test Equipment Plus shall not be liable for any direct, indirect, special, incidental, or consequential damages, whether based on contract, tort, or any other legal theory.

3.1.5 Certification

Test Equipment Plus certifies that, at the time of shipment, this product conformed to its published specifications.

3.1.6 Credit Notice

Windows is a registered trademark of Microsoft Corporation in the United States and other countries.